

# CM1K, the merger of 2 concepts

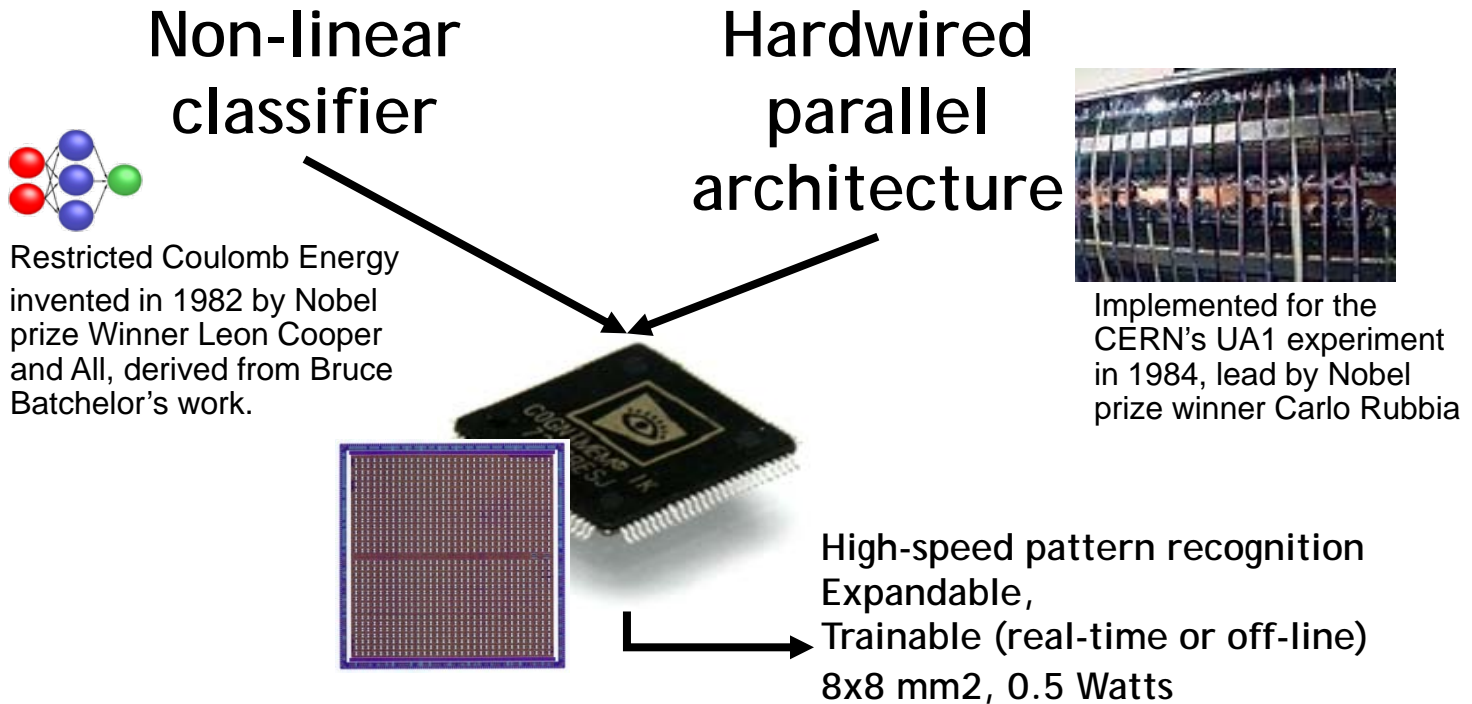

# What is a neuron?

A neuron is a reactive memory which can autonomously evaluate the distance between an incoming vector and a reference vector stored in its memory. If this distance falls within its current influence field, it returns a positive classification.

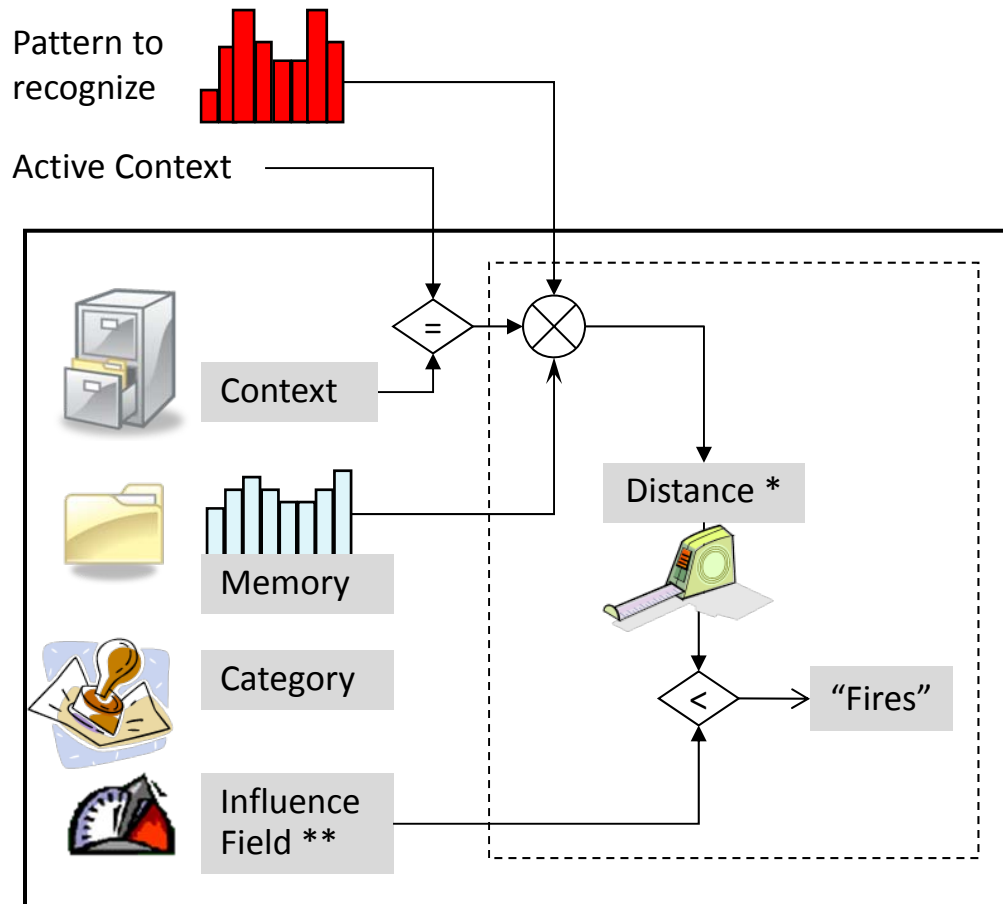

- Calculated by the neuron during the broadcast of the input vector
- \*\* Updated during the learning, if applicable

# What is a neural network?

The true significance of a neuron is its arrangement into a parallel network and ability to Search-And-Sort for best match without sequential access.

## The Winner takes All

→ Learn and recognize a vector in a constant amount of time independent from the number of neurons

→ Network can be expanded at will

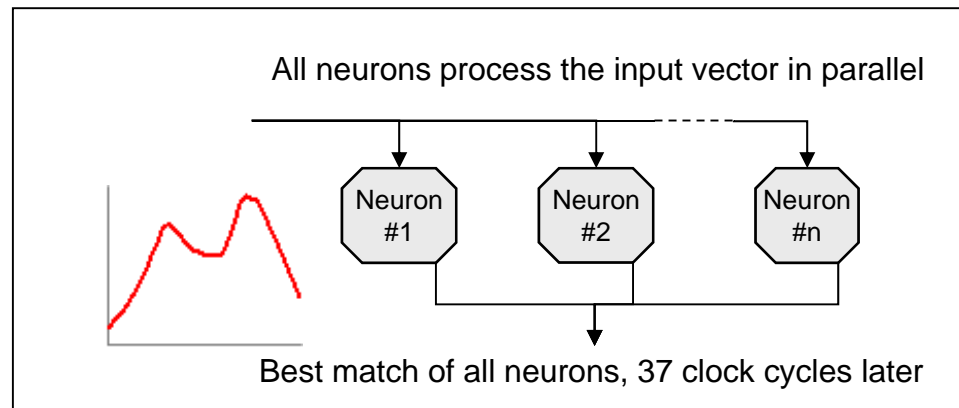

# Neurons = Cognitive Memories

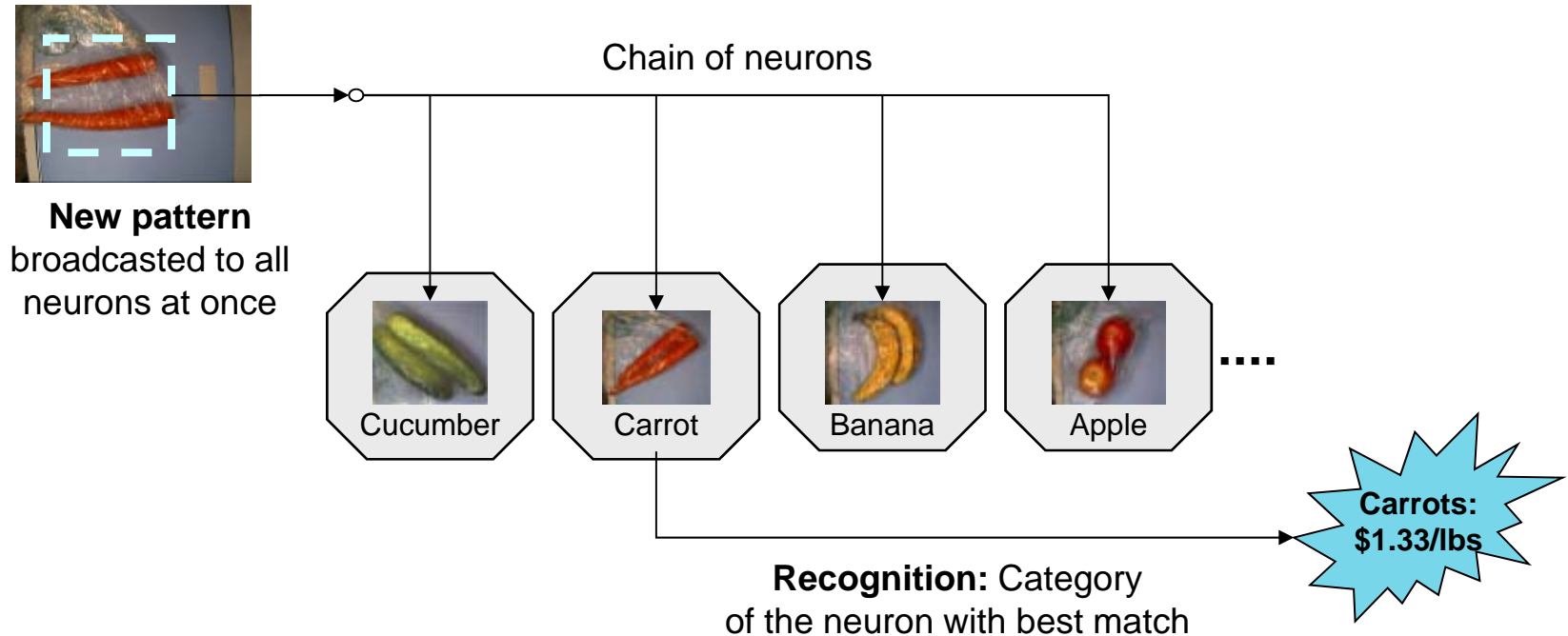

**Neurons** = A component with memory storage and reactive logic to learn and recognize

**Neural network** = A bank of neurons operating together

# A network of neurons in parallel

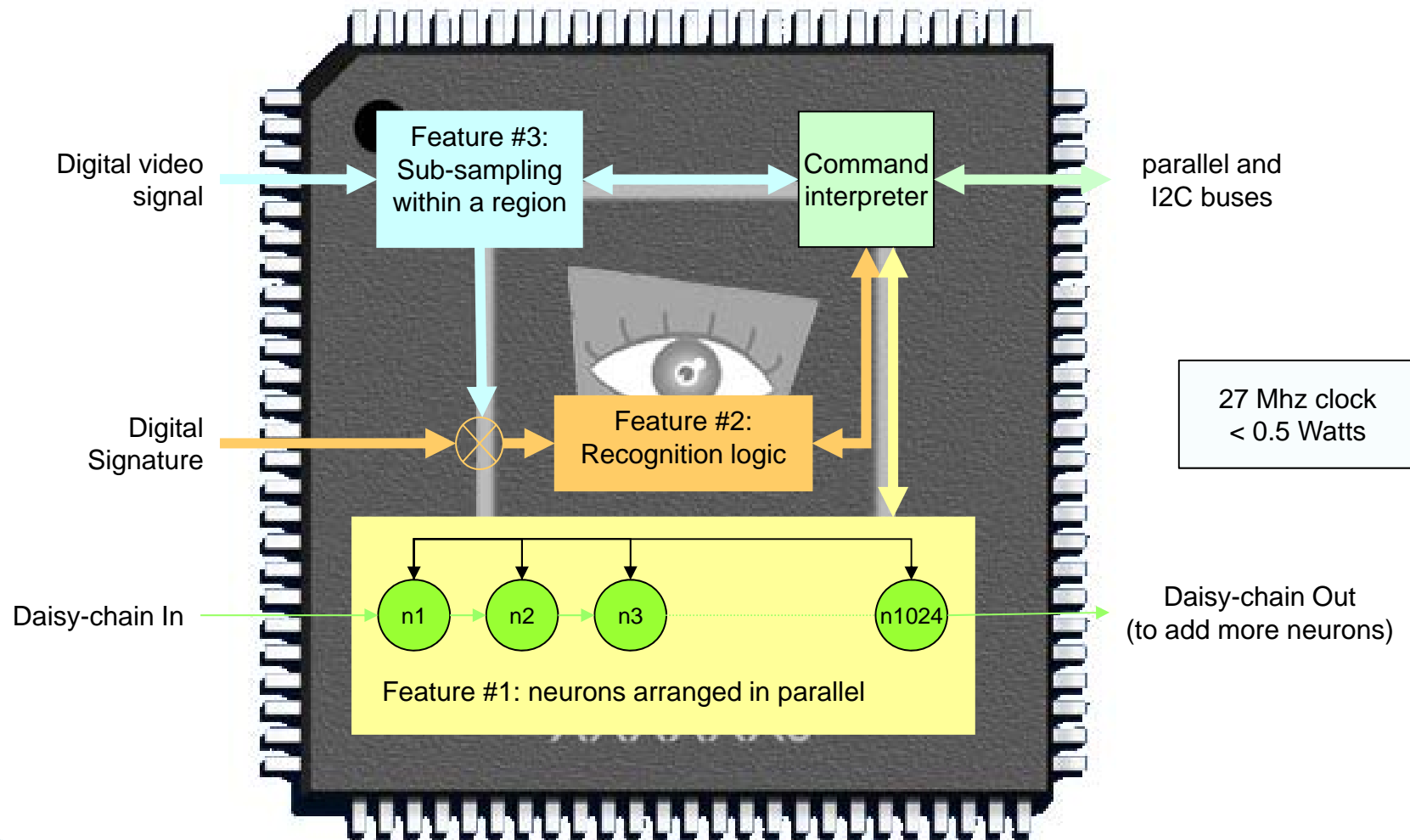

# An adaptive model generator

- Learn by examples (supervised or unsupervised)
- Map decision spaces by aggregates instead of hyper planes
- Cope with non-linear, convex, disjoints and embedded categories
- Possible modulation between conservative and liberal decision spaces with zones of uncertainties
- Save and restore the contents of the neurons
- Can append more training at any time

Learning = Building a “**decision space**” by teaching examples

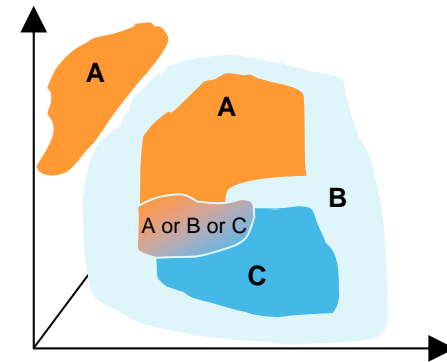

# A high-performance classifier

- Global response readout:
  - positively identified
  - identified with uncertainty
  - unknown
- Detailed response of all the firing neurons
  - category and confidence level (or distance)
  - retrieved per decreasing confidence

Recognition = where does the sample fall in the decision space?

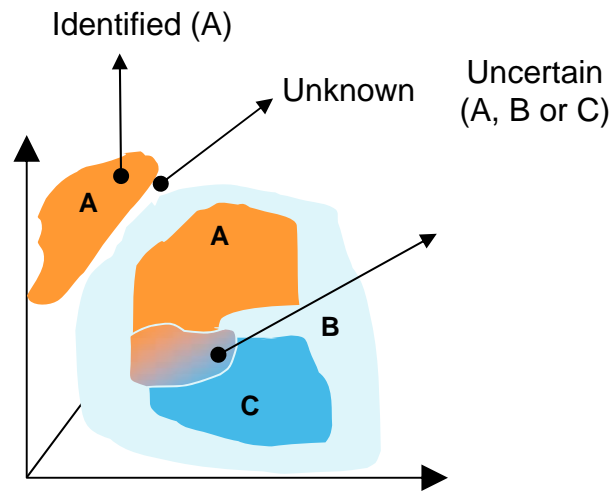

# CM1K Benefits

## Easy to use

- Trained by examples
- Automatic model generator
- Adaptive non-linear classifier
- Knowledge traceability and portability

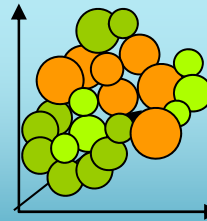

## High-Speed

- Recognition time independent from number of neurons
- Expandable parallel neural network
- Equivalent to >90 DSP @300Mhz

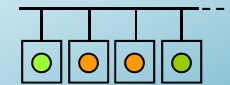

## Easy to integrate

- Low clock frequency
- Low power
- Low pin count connectivity
- Cascadability

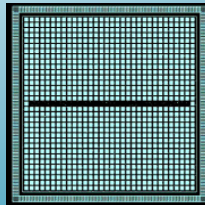

# High speed, Low-power

Find the snail...

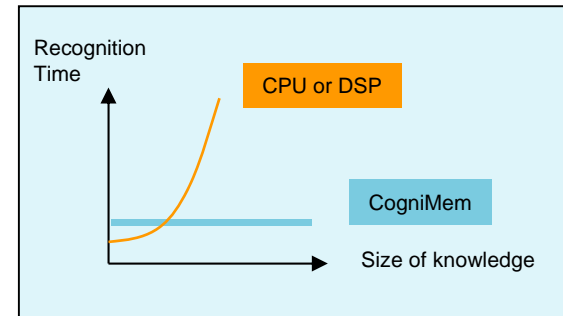
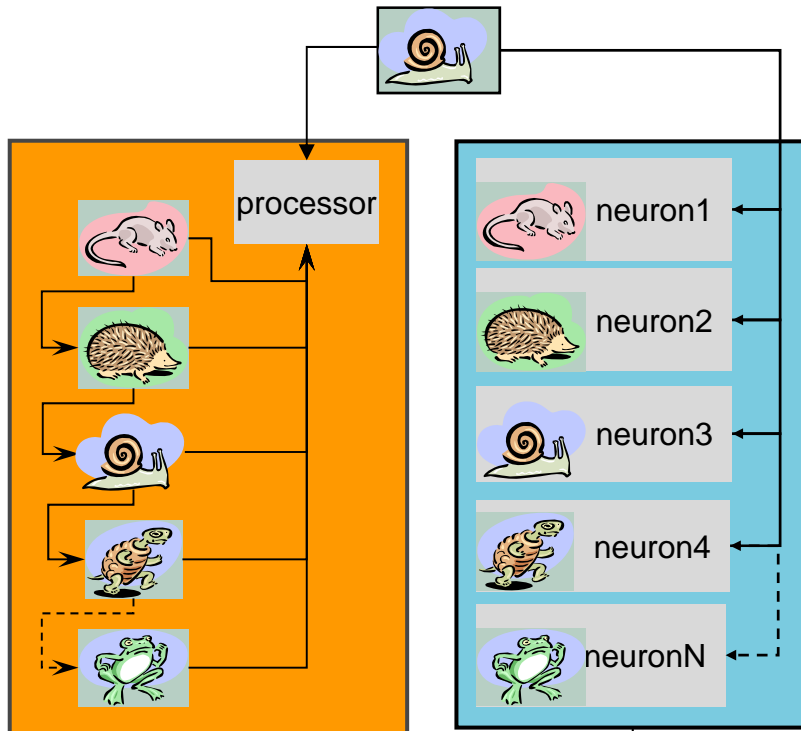

## Peak power consumption

→ Pentium IV @ 2.4GHz → 59W

→ CM1K @ 27Mhz → 0.5 W

→ N CM1K in parallel =  $N \cdot 0.5$  W

CM1K @ 27Mhz

- 9.47 usec to broadcast a pattern of 256 bytes

- 1.3 µsec to find o the best match among N

# Enabler for new architectures

@27 Mhz, the recognition of a 256–bytes vector takes 10.9  $\mu$ sec., equivalent to 91,617 recognition /sec.

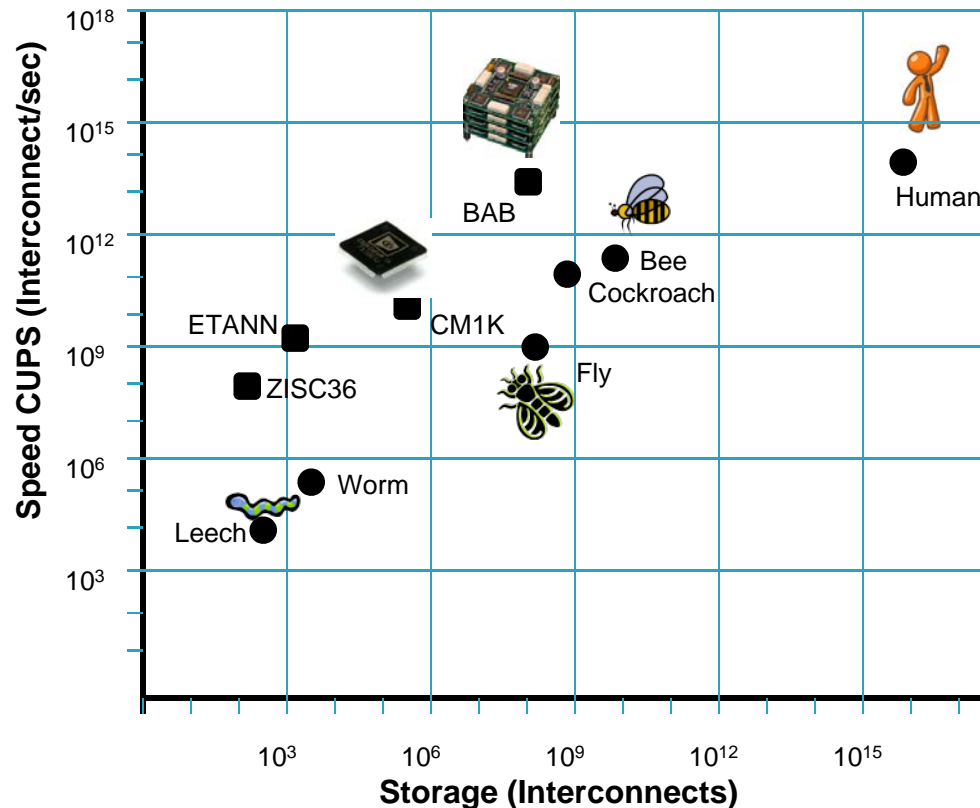

Legend:  
Interconnects:  
CM1K= 256 \* 1024,  
BAB= 1000 CM1K  
CUPS= Connection Update Per Second

# Endless possibilities from Sensors to Servers

Neurons directly connected to a sensor output for real-time recognition at low-cost and low power

Thousand of neurons assembled in parallel for high-speed data mining

