

V1KU is a miniature vision module which offers developers and OEMs a comprehensive platform to evaluate the CogniMem neural network chip for real-time image recognition. The board features a monochrome CMOS sensor, a CogniMem chip with 1024 neurons (CM1K), a Field Programmable Gate Array (FPGA), 16 MB of SDRAM and 4 MB of Flash memory. Communication bus include high-speed USB and RS485 at 3 Mbauds.

The CogniMem chip can learn and recognize pixel data coming directly from the Micron sensor or previously manipulated in the FPGA to produce a feature vector. In the former case, the feature vector is automatically extracted by the CM1K chip from a region of interest defined by the user. The FPGA can also consolidate and format the response of the neural network for transmission to the outside world. The SRAM is partially used to store the memory frame but can also hold user data.

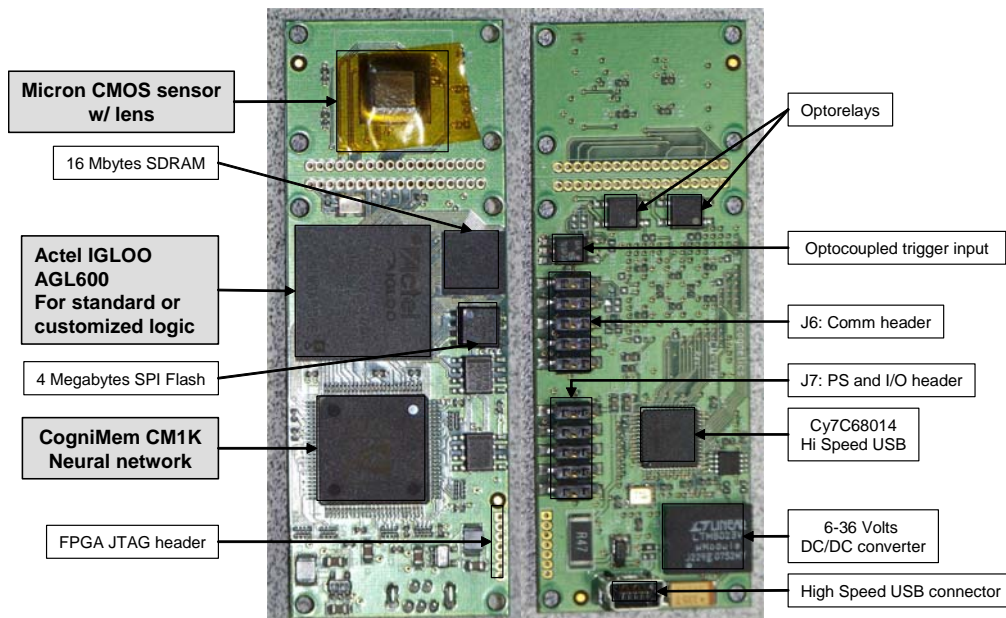

V1KU is delivered with a default CogniSight recognition engine residing in the FPGA. This simple engine recognizes a region of interest 60 times per second. The region can be as small as 16x16 and large as the full video frame. The reported category is the one of the neuron with the best match. The neurons can be trained in real-time or a knowledge can be loaded from file or from the Flash memory.

Applications

Industrial automation

- Presence/Absence
- Pass/Fail, Sorting
- Object identification
- Anomaly detection

Video surveillance

- Selective recording based on image content
- Smart motion detection
- Target tracking
- Face detection

Toys & appliances

- Face recognition
- Image to speech
- Target tracking



The default engine also gives access to the CogniMem neural network through its standard Register Transfer Level (RTL) protocol with possibility to discard the video input.

Programmers can choose to implement their own video signature extraction in the FPGA, move the region of interest, condition the results of the recognition prior to transmission to the user I/Os and more.

Components

Aptina/Micron MT9V022 video sensor

- ✓ Monochrome, Progressive scan
- ✓ 752x480 pixels
- ✓ 60 frames per second
- ✓ Global shutter
- ✓ 6mm M7 lens w/ holder

FPGA

- ✓ Actel IGLOO FPGA (600 Million gates)
- ✓ Default CogniSight engine: recognition of a single region at frame rate, save and restore project to flash memory, usb and uart controller

I/O buses

- ✓ Miniature USB Hi Speed (480 Mbps)
- ✓ I2C serial interface (100-400 kbit)
- ✓ 2 RS485 serial output
- ✓ 1 opto isolated input line
- ✓ 2 opto isolated output lines (<60 v, 500 mA)

Neural network

- ✓ 1024 silicon neurons working in parallel
- ✓ Classify vectors of up to 256 bytes
- ✓ Up to 16382 categories
- ✓ Category readout in 36 clock cycles per firing neuron (i.e. 3 microsecond)
- ✓ Radial Basis Function (Restricted Coulomb Energy) or K-Nearest neighbor classifier
- ✓ Real time self-adaptive model generator

Mechanical and Electrical

- ✓ Powered through USB or external supply
- ✓ 6v to 36v
- ✓ 27 x 7.5 mm
- ✓ Two 10-pin headers
- ✓ 120 grams
- ✓ 1 Watt

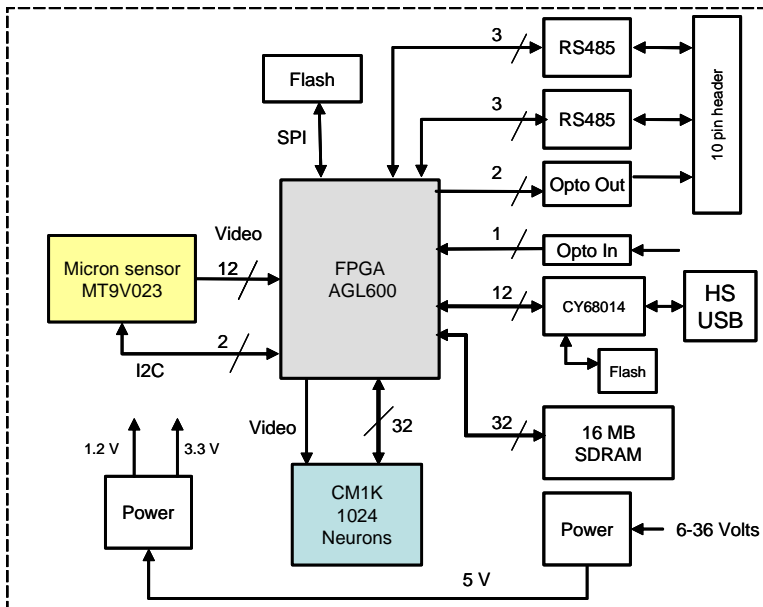

J6 pins	Description
1	RS485 data+ Channel B
2	I2C Clock
3	RS485 data+ Channel A
4	I2C_Data
5	GND power
6	Opto In anode
7	RS485 data- Channel B
8	RS485 data- Channel A
9	6-36 VDC power
10	Opto in cathode
J7 pins	Description
1	6-36 VDC power
2	6-36 VDC power
3	Relay output 0 cathode
4	Relay output 0 anode
5	Relay output 1 anode
6	Relay output 1 cathode
7	Opto In anode
8	Opto in cathode
9	GND power
10	GND power

The functional diagram of a typical CogniSight recognition engine loaded in the FPGA

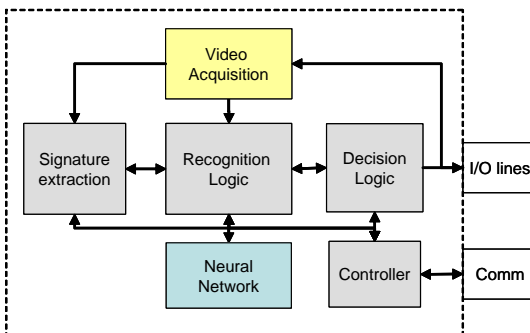

Ordering information

- V1KU, includes
 - Complete hardware documentation
 - Easy Video Trainer software
- Options
 - V1KU SDK for Windows
 - V1KU SDK for FPGA
 - Custom CogniSight engines

General Vision Inc
 Tel: +1 707 765 6150
www.general-vision.com